

2017

PHYSICS

(Major)

Paper : 5.4

(Electronics)

Full Marks : 60

Time : 3 hours

*The figures in the margin indicate full marks
for the questions*

1. Answer the following questions very briefly :

1×7=7

(a) A positive feedback amplifier will oscillate when it satisfies a certain criterion. What is this criterion?

(b) What will be the output voltage when equal voltages are applied to the input terminals of an ideal operational amplifier?

(c) What is ripple factor?

(d) Mention one important merit and one important demerit of RC-coupled amplifier.

- (e) What is the main advantage of CE mode over CB mode of transistor?
- (f) What represents by 00K in binary transmission process?

(g) How is photodiode connected in a circuit?

2. Answer the following questions : 2×4=8

(a) How is varactor diode realised? Where is it used?

(b) There are two basic conditions for oscillation in a feedback amplifier. What are these?

(c) The band gap of a specimen of gallium arsenide phosphide is 1.98 eV. Determine the wavelength of the electromagnetic radiation that is emitted upon direct recombination of electrons and holes in this sample. What is the colour of the emitted radiation?

(d) Draw a TTL NAND gate with totem pole.

3. Draw the circuit diagram of a full-wave rectifier using two P-N junction diodes. Find out the different components present in the output voltage applying Fourier analysis. Draw output voltage pattern when shunt capacitor is used.

2+2+1=5

(3)

Or

Draw the circuit diagram of a tuned collector oscillator along with its a.c. equivalent circuit. Give a brief analysis of it. $2+3=5$

4. Transform the following circuit (Fig. 1) into Thevenin's equivalent circuit and hence find the value of (a) Thevenin's equivalent impedance, (b) Thevenin's equivalent voltage source and (c) load current, if $R_L = 5 \cdot 5 \Omega$.

$2+2+1=5$

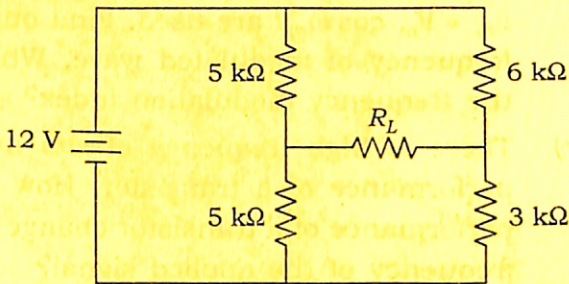

Fig. 1

5. State De Morgan's laws. Show that NOR gate and bubbled AND gate are equivalent to each other. Give their truth tables. $2+3=5$

Or

Describe various current components which flow across the forward-biased emitter junction and the reverse-biased collector junction of transistor.

5

6. Answer any two questions from the following : $5 \times 2 = 10$

- (a) (i) Convert the binary number $1010 \cdot 01_2$ to its decimal equivalent. $1+2+2=5$
- (ii) Convert the decimal number $27 \cdot 375_{10}$ to its binary equivalent.
- (iii) Subtract $10010 \cdot 01_2$ from $111000 \cdot 00_2$ using 2's complement.

(b) For frequency modulation carrier wave, $v_c = V_c \cos \omega_c t$ and modulating signal $v_m = V_m \cos \omega_m t$ are used. Find out the frequency of modulated wave. What is the frequency modulation index? $4+1=5$

(c) There is high frequency effects in the performance of a transistor. How does performance of a transistor change with frequency of the applied signal? 5

(d) Draw the circuit for square-law diode detection. Describe how information is extracted from the received signal. $2+3=5$

7. Answer any two questions from the following : $5 \times 2 = 10$

- (a) What are the different modes of propagation of radio waves? Which of them determines critical frequency? What frequency range of electromagnetic wave is allotted for TV broadcasting? $3+1+1=5$

(b) Draw the circuit diagram of a $J-K$ flip-flop using NAND gate, where preset and clear inputs are incorporated. Explain the operation giving truth table and symbol. 2+3=5

(c) Find out the output voltage v_o of the three-input weighted summing amplifier circuit (Fig. 2). If the maximum permissible output current of the OP-AMP is 20 mA, what is the lowest value of the load resistance R_L ? 5

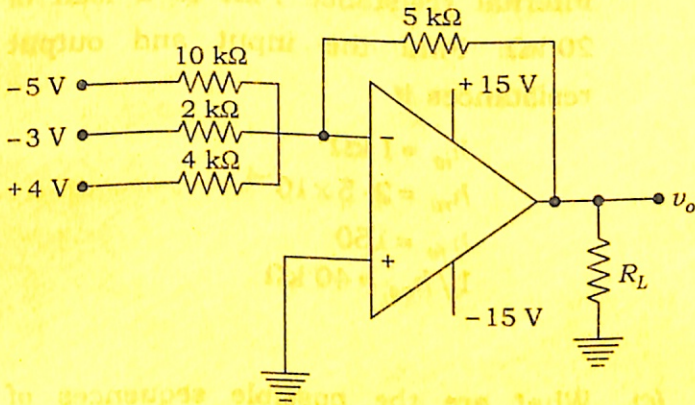

Fig. 2

(d) Draw the circuit of a push-pull (Class-B) amplifier. With the help of brief analysis, show that maximum efficiency is nearly 78.5%. 2+3=5

8. Answer any two questions from the following : 5×2=10

(a) Describe the method by which phase angle between two signals or variable voltages measured by producing Lissajous figures in CRO. 5

(b) A transistor amplifier in CE configuration couples a source of internal resistance $1\text{ k}\Omega$ to a load of $20\text{ k}\Omega$. Find the input and output resistances if

$$h_{ie} = 1\text{ k}\Omega$$

$$h_{re} = 2.5 \times 10^{-4}$$

$$h_{fe} = 150$$

$$1/h_{oe} = 40\text{ k}\Omega$$
5

(c) What are the possible sequences of binary digits used in M-ary communication? If a high frequency carrier wave is used for ASK, FSK and PSK, then what will be the pattern of modulated signal if a particular digital modulating signal is assumed? 2+3=5

(7)

(d) Write a short note on any *one* of the following :

5

- (i) Astable multivibrator
- (ii) Barkhausen criterion
- (iii) Maximum power transfer theorem and mixed combination of identical cells in circuit
